

PLASTRULON

THE ANSWER TO CORROSION

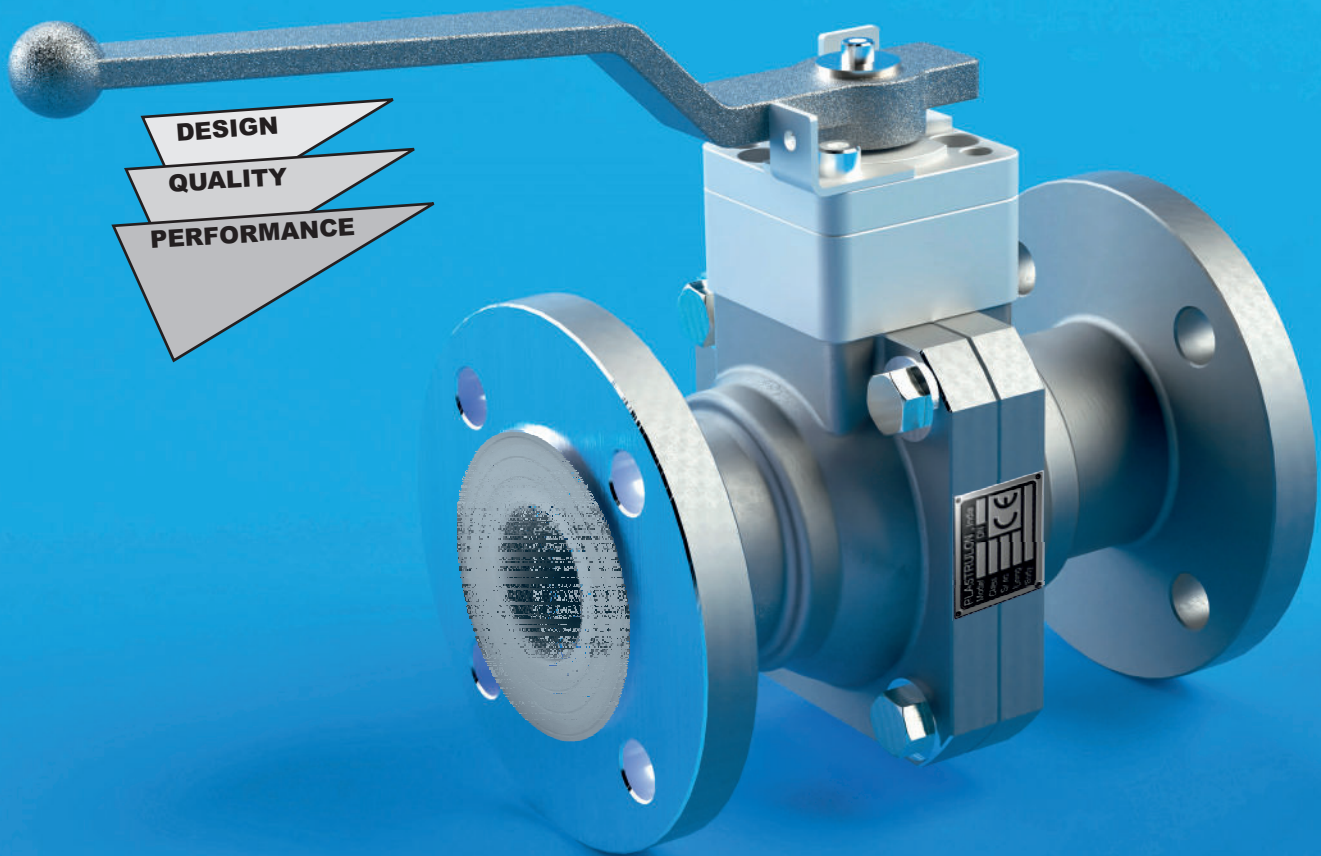

STAINLESS STEEL
PLASTIC LINED FULL PORT
CENTER SPLIT
DIN PN 10/16

BALL VALVE

LININGS : PFA (FDA APPROVED)

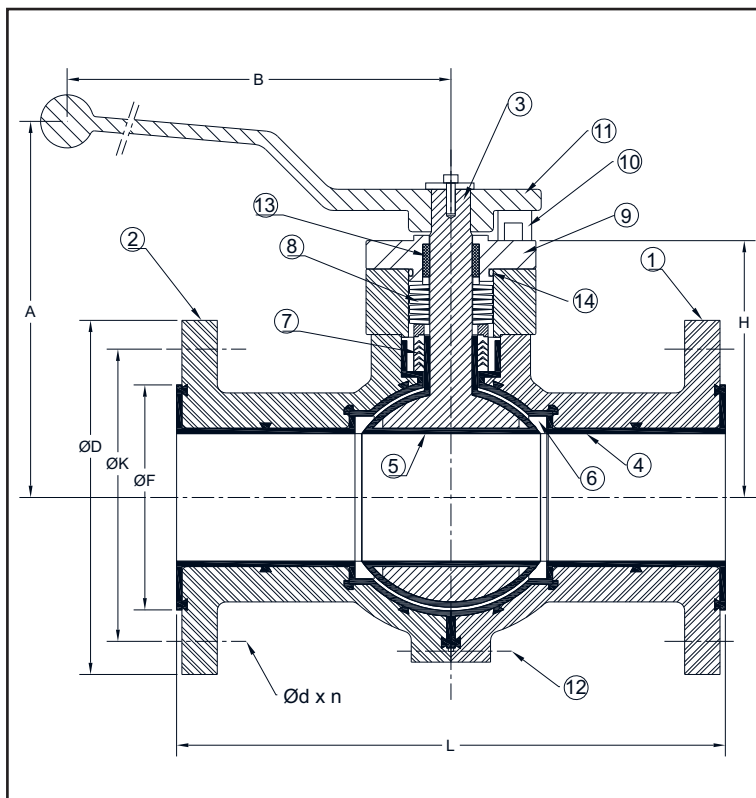

DIMENSIONS		in mm.						
SIZE IN.	1/2"	3/4"	1"	1 1/2"	2"	3"	4"	6"
DN	15	20	25	40	50	80	100	150
L	130	150	160	200	230	310	350	480
H	77	99	99	104	112	145	181	228
ØD	95	105	115	150	165	200	220	285
Ød x n	14 x 4	14 x 4	14 x 4	18 x 4	18 x 4	18 x 8	18 x 8	23 x 8
K	65	75	85	110	125	160	180	240
B	150	175	175	225	250	300	350	600
A	95	129	129	166	175	220	265	308
F	35	43	51	73	92	127	157	216

SIZE		APPROX. WEIGHT		TORQUE, Kgm @ ΔP=10 bar / 150psi		FLOW RATE	
inch	DN	lb.	Kg.	Oper.	Max. permitted	m3/h	US gpm
1/2"	15	7.0	3.2	0.4-0.6	1.2	18	20.5
3/4"	20	14	6.2	0.6-1.2	2	61	70.5
1"	25	15	6.6	0.6-1.2	2	61	70.5
1 1/2"	40	29	13	1.2-2.4	5	189	219
2"	50	35	16	2.5-3.5	8	277	321
3"	80	75	34	4.0-6.0	16	598	692
4"	100	117	53	6.0-9.0	32	1254	1451
6"	150	234	106	16-20	50	2778	3215

MATERIAL SPECIFICATION

No.	Description	Standard Material	Optional Material	Qty.
1	Body A	ASTM A351 Gr. CF8M	ASTM A351 Gr. CF8	1
2	Body B			1
3	Ball-Stem	ASTM A351 Gr. CF8M	ASTM A351 Gr. CF8	1
4	Body Lining	PFA (FDA Approved)		1
5	Ball lining	PFA (FDA Approved)		1
6	Seat ring set	M-PTFE (TFM)	PTFE	1
7	Packing ring set	M-PTFE (TFM)	PTFE	1
8	Disc spring set	AISI 304	AISI 304	1
9	Packing Gland Cover	ASTM A351 CF8M	ASTM A351 Gr. CF8	1
10	Lever stopper (Lockable)	AISI 316	AISI 304	1
11	Lever	ASTM A351 Gr. CF8M	ASTM A351 Gr. CF8	1
12	Fasteners set	ASTM 193 GR. B8M	ASTM A194 B8	1
13	Secondary Stem Seal	PTFE-GRAPHITE	PTFE	1
14	O-Ring	VITON		1

TECHNICAL DATA

Pressure range : 0-16 bar (refer P&T chart)
 Temperature range : (-) 60 -200 °C (refer P&T chart)
 Vacuum resistance : Full vacuum (refer P&T chart)
 Face to face : DIN 3202/F1
 options- ANSI B16.10 Short pattern / Long Pattern.
 Flange drilling : DIN PN 10/16
 options- ANSI B16.5-150# / 300#

OPTIONAL PRODUCT CONFIGURATIONS

- Special 'V' port ball for improved flow control.
- Ball valve with extended stem and ISO 5211 actuator mounting flange.
- Ball Valve with actuator mounted using a bracket and adapter.
- Manually Operated Ball Valve with Lockable lever.



PLASTRULON make Lined Ball valves can be supplied with CE mark as per EU Pressure Equipment Directive 2014/68/EU (PED). Valves are inspected and certified as CE compliant by PED Notified body.



PLASTRULON make valves do not have their own potential ignition source, hence not considered to be an equipment under the scope of the ATEX Directive 2014/34/EU.



PLASTRULON

PLASTRULON PROCESSORS PVT. LTD.
 B102 Sagar Garden, LBS Road,
 Mulund (W), Mumbai 400080. India.
 Tel. : 91 22 25602533 / 25610520
 Email : sales@plastrulon.global
 Website : www.plastrulon.global

Plastrulon PFA Lined Full Bore Ball Valve ANSI Short pattern (New Design)					
Size	Description	Operating torque (no safety)			
		KGM		NM	
		$\Delta P = 10$ barg	MAST	$\Delta P = 10$ barg	MAST
1/2"	FB11TTT - 150	0.4 - 0.6	1.2	4 - 6	12
3/4"	FB11TTT - 150	0.6 - 1.2	2	6 - 12	20
1"	FB11TTT - 150	0.6 - 1.2	2	6 - 12	20
1.5"	FB11TTT - 150	1.2 - 2.4	5	12 - 24	49
2"	FB11TTT - 150	2.5 - 3.5	8	24 - 34	78
3"	FB11TTT - 150	4 - 6	16	39 - 59	157
4"	FB11TTT - 150	6 - 9	32	59 - 88	314
6"	FB11TTT - 150	16 - 20	50	157 - 196	490

Plastrulon PFA Lined Full Bore Ball Valve DIN Long pattern (New Design)					
Size	Description	Operating torque (no safety)			
		KGM		NM	
		$\Delta P = 10$ barg	MAST	$\Delta P = 10$ barg	MAST
1/2"	FB21TTT - PN16	0.4 - 0.6	1.2	4 - 6	12
3/4"	FB21TTT - PN16	0.6 - 1.2	2	6 - 12	20
1"	FB21TTT - PN16	0.6 - 1.2	2	6 - 12	20
1.5"	FB21TTT - PN16	1.2 - 2.4	5	12 - 24	49
2"	FB21TTT - PN16	2.5 - 3.5	8	24 - 34	78
3"	FB21TTT - PN16	4 - 6	16	39 - 59	157
4"	FB21TTT - PN16	6 - 9	32	59 - 88	314
6"	FB21TTT - PN16	16 - 20	50	157 - 196	490

Torque figures are based on a lubricated duty and are constant.